DEPARTMENT OF THE ARMY TECHNICAL BULLETIN

**QUICK REACTION TRIMBLE TRIMPACK GLOBAL
POSITIONING SYSTEM (GPS) SPECIAL MISSION
INSTALLATION, UH-1H AND UH-1V HELICOPTERS**

Headquarters, Department of the Army, Washington, D.C.

31 December 1994

DISTRIBUTION STATEMENT A: Approved for public release; distribution is unlimited.

1. **Summary.** This Technical Bulletin adds provisions for temporary installation of a GPS Trimpack receiver in the cockpit on the left side of copilots pedestal and a remote Antenna located on the upper wire strike cutter.
2. **Purpose.** This installation, when the GPS Trimpack is installed, will provide the Copilot/Observer with information on aircraft position for navigation.
3. **Priority Classification. ROUTINE.**
4. **Applicable end item(s) or system(s).**

NOMENCLATURE	NSN	CAGE	MODEL	S/N
Helicopter	1520-00-087-7637	97499	UH-1H	**
Helicopter	1520-01-043-4949	97499	UH-1V	**

An air worthiness release is required for each aircraft serial number. Prior approval is required of this installation from each unit's MACOM. Units requesting installation kits are required to provide their request for kits by aircraft type, model, series, serial number and unit through their MACOM to PM avionics, ATTN: SFAE-AV-EL, 4300 Goodfellow Blvd. St. Louis, Mo. 63120-1798. PM avionics will request an air worthiness release from AVSCOM Directorate for Engineering and provide the installation kit.

*This is a revision of TB 1-1520-210-20-17, dated 1 January 1991.

5. Assembly Components to be Installed.

NOMENCLATURE	NSN	CAGE	PART NO.	WEIGHT
Kit A	5895-01-340-5494	20309	90209222-501	5.0 lbs.
Kit B				
Antenna, GPS		65457	# 12038-00 or # 16248-40	0.3 lbs.
Receiver, Trimble Trimpack		65457	# 16768-10 or # 16768-20	4.2 lbs.
ANVIS Mod. Kit	5895-01-340-5502	80063	# A3L54590-2	1.0 lbs.

DA has directed distribution of B. kits for post Desert Storm environment. Sets will be distributed according to a prioritization established and directed by HQDA with assistance from U.S. Army Combined Arms Command. Questions concerning distribution should be addressed to Mr. Rusty Keller, PM GPS, (SFAE-CM-GPS-DPM), Ft. Monmouth, NJ. 07703-5000 (DSN 992-6061)

6. Parts to be Installed.

Contents of Kit A

NOMENCLATURE	NSN	CAGE	PART NO	QUANTITY
Cable, Power	*	20309	90209183-502	1
Cable, Antenna, lower	*	20309	90209182-502	1
Cable, Antenna, upper	*	20309	90209182-503	1
Connector, RF bulkhead	5935-01-043-0648	81349	M39012/28-0101	1
Mount, Antenna, LS	*	20309	90209215-4	1
Mount, Antenna, RS	*	20309	90209215-3	1
Mount, Trimpack	*	20309	90209215-1	1
(for Sleeve/Adapter)				
Panel, Antenna Blankoff	*	20309	90209175-501	1
Sleeve/Adapter	*	20309	90209178-501	1
(for Trimpack mounting)				
Template	*	20309	90209215-2	1
TyWraps	5975-00-984-6582	96906	MS3367-1-0	20
Bolt	5306-00-151-0785	88044	AN3-7A	2
Screw	5305-00-989-7434	96906	MS35207-263	8
Screw	5305-00-984-6195	96906	MS35206-247	4
Washer, Flat	5310-00-167-0812	88044	AN960C10L	16
Washer, Flat	5310-00-558-6207	88044	AN960C8L	4
Washer,	5310-01-131-2259	88044	AN960JD816L	2
Nut, Self Locking	5310-01-680-4892	96906	NA5679A3W	4
Nut, Self Locking	5310-00-807-1474	96906	MS21042-L3	2
Grommet	5325-00-276-6091	96906	MS335489-19	1
Terminal Lug	5940-00-204-8966	96906	MS25036-102	2
Circuit Breaker	5925-00-929-7716	96906	MS26574-1	1
Placard	*	20309	90209215-7	1
Jumper	*	20309	90209215-8	1
Plate	9905-00-944-1740	97499	204-075-289-1	1
Template, Ant	*	20309	90209215-5	1
Mount Clamp	5340-00-291-5322	96906	MS21919WDG3	2

* NSN To Be Assigned

Contents of Kit B (Obtain as individual Components through supply).

NOMENCLATURE	NSN	CAGE	PART NO	QUANTITY
Antenna, GPS	5985-01-326-5583	65457	# 12038-00 or # 16248-40	1
Receiver, Trimble Trimpack		65457	# 16768-10 or # 16768-20	1
ANVIS Mod. Kit	5895-01-340-5502	80063	A3L5490-2	1

DA has directed distribution of B. kits for post Desert Storm environment. Sets will be distributed according to a prioritization established and directed by HQDA with assistance from U. S. Army Combined Arms Comm- and Questions concerning distribution should be addressed to Mr. Rusty Keller, PM GPS, (SFAE-CM-GPS-DPM) Ft. Monmouth, NJ. 07703-5000 (DSN 992-6061)

NOTE

Refer to the small light weight Global Positioning system Receiver support plan for Trimble Trimpack dated July 1991 for training support and return or repair instructions for failed Trimble Trimpack equipment.

7. Application.

- a. Catagory of Maintenance: Aircraft downtime will be charged to AVUM Maintenance.
 - (1) AVIM for Kit A installation.
 - (2) AVUM for Kit A removal and Kit B installation/removal.
- b. Time required for Kit A installation. Work force and Man Hour requirements for application of this Technical Bulletin is as follows:

WORK FORCE/SKILLS	MAN/HOURS
Aircraft Electrician	4
Sheet Metal Repairer	1

Total man-hours required for this application is: 5 hours.

- c. TB/MWO(s) to be Applied Prior to or Concurrently With This Technical Bulletin: None.

8. Publications which require a change as a result of this Technical Bulletin. None.

NOTE

Operator and Maintenance Guide will be provided with GPS Trimpack Receiver.

9. Supply/Parts and Disposition.

- a. Expendable supplies required.

NOMENCLATURE	NSN	CAGE	PART NO.
Alodine	8030-01-018-2838		MIL-C-5541
Primer	8010-00-582-5318		MIL-P-23377
sealant	8030-00-723-2746		ML-S-8802 TYPE II, CLASS A 1/2
Tape, Pressure Sensitive	7510-00-283-0612		PPP-T-42

10. Special tools, Jigs and Fixtures required.

NOMENCLATURE	NSN	CAGE	PART NO	QUANTITY
Multimeter	6625-00-999-7465		AN/USM-223	1

11. Kit A Installation Procedure.

- a. Preliminary Procedure. Inventory the kit to assure completeness.

NOTE

Refer to TM 55-1520-210-23 and TM 11-1520-210-20 for detailed removal and installation instructions not specified herein and to TM 55-1520-210-23P for detailed parts location.

Refer to TM 55-1500-323-24 for detailed instructions concerning aircraft electrical and electronic wiring installation practices.

Refer to TM 1-1500-204-23-10 for detailed instructions concerning aircraft sheetmetal modification/installation practices.

NOTE

To prepare helicopter for safe ground maintenance battery must be disconnected.

- b. Prepare the aircraft for safe ground maintenance (TM 55-1520-210-23).
- c. Removal procedure.
 - (1) Open nose compartment door.
 - (2) Remove access panel from left side of copilot pedestal
 - (3) Gain access to overhead console circuit breaker and wiring.
 - (4) Remove upper cabin sound proofing blanket as required to gain access to wire bundles and GPS antenna cable routing.

(5) Remove Windshield center post cover and gain access for wire routing behind main instrument panel.

(6) Remove the following components from copilots pedestal for access to install GPS provisions (refer to TM 55-1520-210-23):

Transponder Control	(APX-72)
Omni Control	(ARN-82)
VHF Control	(ARC-134)
UHF Control	(ARC-51)

Blank panel between VHF Control (ARC-134) and UHF Control (ARC-51).

d. Install 90209215-3 and -4 Trimpack remote antenna mounts. see Figure 1.

(1) Position 9020215-5 template on saw blade of upper wire strike cutter with template aligned with aft edge of saw blade as shown in Figure 1. Drill pilot holes to locate GPS antenna mounting holes. Remove template. Drill holes to size (0.198).

(2) Deburr holes and touch up rework area using Alodine ME-C-5541 and primer MIL-P-23377.

(3) Install 90209-215-3 and 90209215-4 antenna mounts on upper wire strike cutter holes drilled in step 1. Secure mounts to cutter (see Figure 1) with two AN3-7A bolts, four AN960C10L washers and two MS21042-L3 nuts.

e. Installation of the GPS Trimpack mount (P/N 90209215-1) and Trimpack sleeve Assembly (P/N 90209178-501) on left hand side of Copilots pedestal access panel, see Figure 2.

(1) Install P/N 90209215-2 Template on access panel with three alignment holes over Zdots fasteners as shown in Figure 2. Drill four pilot holes to locate Trimpack mount (P/N 90209215-1). Also drill pilot hole to locate antenna cable access (feed through) hole. Remove Template.

(2) Drill four mounting plate holes to size (0.204).

(3) Deburr holes and touch up rework area using Alodine, MIL-C-5541 and primer MIL-P-23377.

(4) Install the mounting plate (P/N 90209215-1) on the access panel with four screws (MS35207-263), four washers (AN960C10L) and four nuts (NAS679A3W).

(5) Drill 0.437 inch hole in access panel for cable access hole located in step (1). Install (MS35489-19) grommet in access hole (see Figure 2).

(6) Install access panel with Trimpack mount plate on copilots pedestal.

(7) Install Trimpack sleeve assembly (P/N 90209178-501) on Trimpack mount plate attached to access panel on Copilots pedestal and secure with four screws (MS35207-263) and four washers (AN960C10L).

f. Installation of aircraft wiring for Trimpack GPS.

(1) Install MS26574-1 circuit breaker in blank space in overhead console, see Figure 3. Install 204-075-289-1 plate and 90209215-7 placard to identify GPS circuit breaker.

TB 1-1520-210-20-17

(2) Starting at Trimpack mount on left side of copilots pedestal, route Trimpack power cable long wire through Grommet in GPS antenna feed-thru hole in pedestal access cover, forward under main instrument panel, up left side of windshield center post and aft along cabin overhead wire bundles to GPS circuit breaker on overhead console. Install MS25036-102 terminal lug on wire and connect wire to load side of GPS circuit breaker, see Figure 3.

(3) Install 90209215-8 jumper from line side of PILOT & R INTER COM circuit breaker to line side of GPS circuit breaker, see Figure 3.

(4) Starting at Trimpack mount on left side of copilots pedestal, route 90209183-502 power cable ground wire through Grommet in GPS antenna feed-thru hole in pedestal access cover forward along existing wire bundles behind main instrument panel into nose compartment to grounding bus (TB29) as shown in Figure 3. Install M792814-149 terminal lug on ground wire and connect to TB29 grounding bus.

(5) Locate and drill feed-thru hole (D-hole) for RF bulkhead connector in upper cabin structure, see Figure 3.

(6) Deburr hole and touch up rework area using Alodine, MIL-C-5541 and MIL-P-23377.

(7) Starting at the Trimpack mount on left side of copilots pedestal, route 90209182-502 Trimpack remote antenna cable (end without connector) through Grommet in GPS antenna feed-thru hole in pedestal access cover, forward along existing wire bundles, under main instrument panel, up left side of windshield center post, and aft along cabin overhead wire bundles to RF connector hole drilled in step (5), see Figure 3.

(8) Cut antenna cable to length and install M39012/28-0101 RF bulkhead connector on end of cable, see Figure 3.

(9) Install antenna cable with RF bulkhead connector with seal in hole drilled in step (5). Secure connector extending through upper skin with two AN960JD816L washers, MIL-S-8802 scalant, lockwasher and nut, see Figure 3.

(10) On upper exterior surface of cabin, connect 90209182-503 antenna cable to RF connector installed in step (9) above and route cable to GPS antenna mount on wire strike cutter, see Figure 3.

(11) Connect antenna cable to antenna blankoff panel connector and install 90209175-501 antenna blankoff panel to GPS antenna mount and secure with four MS35206-247 screws and four AN960C8L washers, see Figure 3.

(12) Secure cable on upper cabin structure with MS21919WDG3 clamps and tywraps as required (see Figure 3).

(13) Secure power cable and antenna cable to existing wire bundles using tywraps.

g. Final procedures.

(1) Perform a continuity check on the coax cable for the Trimpack remote antenna.

(2) Install Windshield center post cover.

(3) Install the following components on copilots pedestal (refer to TM 55-1520-210-23):

Transponder Control	(APX-72)
Omni Control	(ARN-82)
VHF Control	(ARC-134)
UHF Control	(ARC-51)

Blank panel between VHF Control (ARC-134) and UHF Control (ARC-51).

- (4) Close access to overhead console circuit breaker and wiring.
- (5) Install overhead cabin sound proofing blanket.
- (6) Close nose compartment door.
- (7) Connect the aircraft battery.
- (8) Turn power on to provide 28 volts to GPS circuit breaker on center post circuit breaker panel.
- (9) Verify pin B of the GPS five pin audio connector is common with airframe ground and that pin D (see Figure 4) has 28 VDC on it.
- (10) (Optional) Install the Trimpack unit (See note in paragraph 1) and remote antenna in the aircraft. Move the aircraft to outside ramp with good GPS satellite visibility. Power up the aircraft. Turn the Trimpack on and check to see that it acquires the GPS satellites which are visible at the time of the test

12. Kit B Installation Procedure.

- a. Remove GPS antenna blankoff panel (if installed) from the GPS antenna mount on upper wire strike cutter of aircraft (see Figure 5).
- b. Install GPS antenna on its mount and secure with four MS35206-247 screws and four AN960C8L washers (see Figure 5).

NOTE

To facilitate removal, do not seal the antenna to its mount.

NOTE

Only Trimble Trimpack GPS receiver part number 16768-10 and 16768-20 are allowed for this installation. These receivers have software to compensate for rotor modulation and have green lights. All other Trimble Trimpacks receivers can not be used. The part number is on a nameplate located between the receiver and battery pack. The battery pack must be removed to see the nameplate. An ANVIS night vision imaging filter kit, NSN 5895-01-340-5502 provides an acceptable display when used with either GPS receiver. Instructions for ANVIS filter installation are contained in ILS 9L-ANV0002, dated March 1991, provided with ANVIS kit.

- c. Remove caps from GPS Trimpack receiver power connector and external antenna cable connector. Tape caps to side of receiver with pressure sensitive tape PPP-T-42 to prevent chafing.
- d. Install receiver in its mount on copilots pedestal and secure with clamp assemblies. Connect power cable and antenna cable to the receiver.
- e. Move the aircraft to outside ramp with good satellite visibility. Power up aircraft Turn the Trimpack on and check to see that it acquires the GPS satellites which are visible at the time of the test

NOTE

If the Trimpack receiver is removed from the aircraft and operated on its internal batteries, the external power connector cap must be reinstalled.

13. Kit B Removal Procedure.

- a. Remove GPS antenna from its mount and disconnect GPS antenna cable.
- b. Connect GPS antenna cable to antenna blankoff panel and install blankoff panel on GPS antenna mount. Secure blankoff panel to mount using screws and washers.
- c. Remove Trimpack receiver from its mount on copilots pedestal and disconnect antenna cable and power cable. Install caps on Trimpack receiver connectors.

14. Kit A Removal Procedures.

NOTE

To prepare helicopter for safe ground maintenance battery must be disconnected.

- a. Prepare the aircraft for safe ground maintenance (TM 55-1520-210-23).
- b. Open nose compartment door.
- c. Gain access to overhead console circuit breaker breakers and wiring.
- d. Remove upper cabin sound proofing blanket as required to gain access to wire bundles and GPS antenna cable routing.
- e. Remove Windshield center post cover and gain access for wire routing behind main instrument panel.
- f. Remove the following components from copilots pedestal for access to install GPS provisions (refer to TM 55-1520-210-23):

Transponder Control	(APX-72)
Omni Control	(ARN-82)
VHF Control	(ARC-134)
UHF Control	(ARC-51)

Blank panel between VHF Control (ARC-134) and UHF Control (ARC-51).

- g. Remove 90209215-3 and -4 Trimpack remote antenna mounts from upper wire strike cutter.
 - (1) Disconnect antenna cable from blankoff panel and remove blankoff panel from antenna mount. Remove upper antenna cable.
 - (2) Remove left and right antenna mounts from upper wire strike cutter.
- h. Remove aircraft wiring for Trimpack GPS.

(3) Remove GPS circuit breaker from overhead console, see Figure 3. Remove GPS placard from GPS circuit breaker panel.

(4) Disconnect power cable ground wire from grounding bus (TB29) in nose compartment

(5) Remove tywraps and remove GPS power cable from the aircraft.

(6) Remove clamps and tywraps from antenna cable on upper surface of cabin. Disconnect cable from RF bulkhead connector and remove cable.

(7) Remove tywraps from 90209182-502 lower antenna cable and remove cable from the aircraft.

(8) Remove RF bulkhead connector from hole in upper cabin structure.

(9) Patch/repair hole in upper cabin structure in accordance with TM 1-1500-204-23-10.

i. Remove GPS Trimpack mount (P/N 90209215-1) and Trimpack sleeve assembly (P/N 90209178-501) from access panel on copilots pedestal, see Figure 1.

(1) Remove Trimpack sleeve Assembly from Trimpack mounting plate by removing the four screws.

(2) Remove access panel with Trimpack mounting plate from copilots pedestal.

(3) Remove Trimpack mounting plate from access panel by removing four screws, washers and nuts.

(4) Remove grommet from antenna access hole in access panel.

(5) Patch/repair holes in access panel in accordance with TM 1-1500-204-23-10.

(6) Reinstall access panel on copilots pedestal.

j. Install Windshield center post cover.

k. Install the following components on copilots pedestal (refer to TM 55-1520-210-23):

Transponder Control	(APX-72)
Omni Control	(ARN-82)
VHF Control	(ARC-134)
UHF Control	(ARC-51)

Blank panel between VHF Control (ARC-134) and UHF Control (ARC-51).

l. Close access to overhead console circuit breaker breakers and wiring.

m. Install overhead cabin sound proofing blanket.

n. Close nose compartment door.

o. Connect the aircraft battery.

15. Weight and Balance Data.

Weight and balance for this Technical Bulletin as shown on form 365A.

Component	Wt (lbs.)	Arm (in.)	Moment/100 (in lbs.)
Kit A			
Receiver Mount/Adapter Bracket	1.3	39	0.51
Wiring	1.1	25	0.28
Antenna Mount	0.5	29	0.15
Kit B			
Antenna	0.3	29	0.1
Receiver, Trimpack	4.2	39	1.6

16. Recording and Reporting Requirements.

a. Record and Reports. Record accomplishment of this Technical Bulletin in accordance with the procedure prescribed in DA PAM 738-751. The following forms are applicable:

- (1) DA Form 5504 (Maintenance Request) (Standard Army Maintenance System).
- (2) DA Form 2407 (Maintenance Request) (For Non SAMS Activity).
- (3) DA Form 2408-5 Equipment Modification Record.
- (4) DA Form 2408-13 Aircraft Maintenance Record.
- (5) DA Form 2408-15 Historical Record for Aircraft.

17. Points of Contact for this Technical Bulletin.

a. Technical is Mr. Arlie Keister, SAVAA-I, DSN 995-2040 or commercial (908) 544-2040 or Mr. Peter Nyquist, SAVAA-I, DSN 995-3542 or commercial (908) 544-3542.

b. Logistical is Ms. Vilna Mentel, SAVAA-ILS, DSN 995-4175 or commercial (908) 544-4175.

c. Forms and Records is Mr. Larry Young, AMSAV-MMD, DSN 693-1955 or commercial (314) 263-1955.

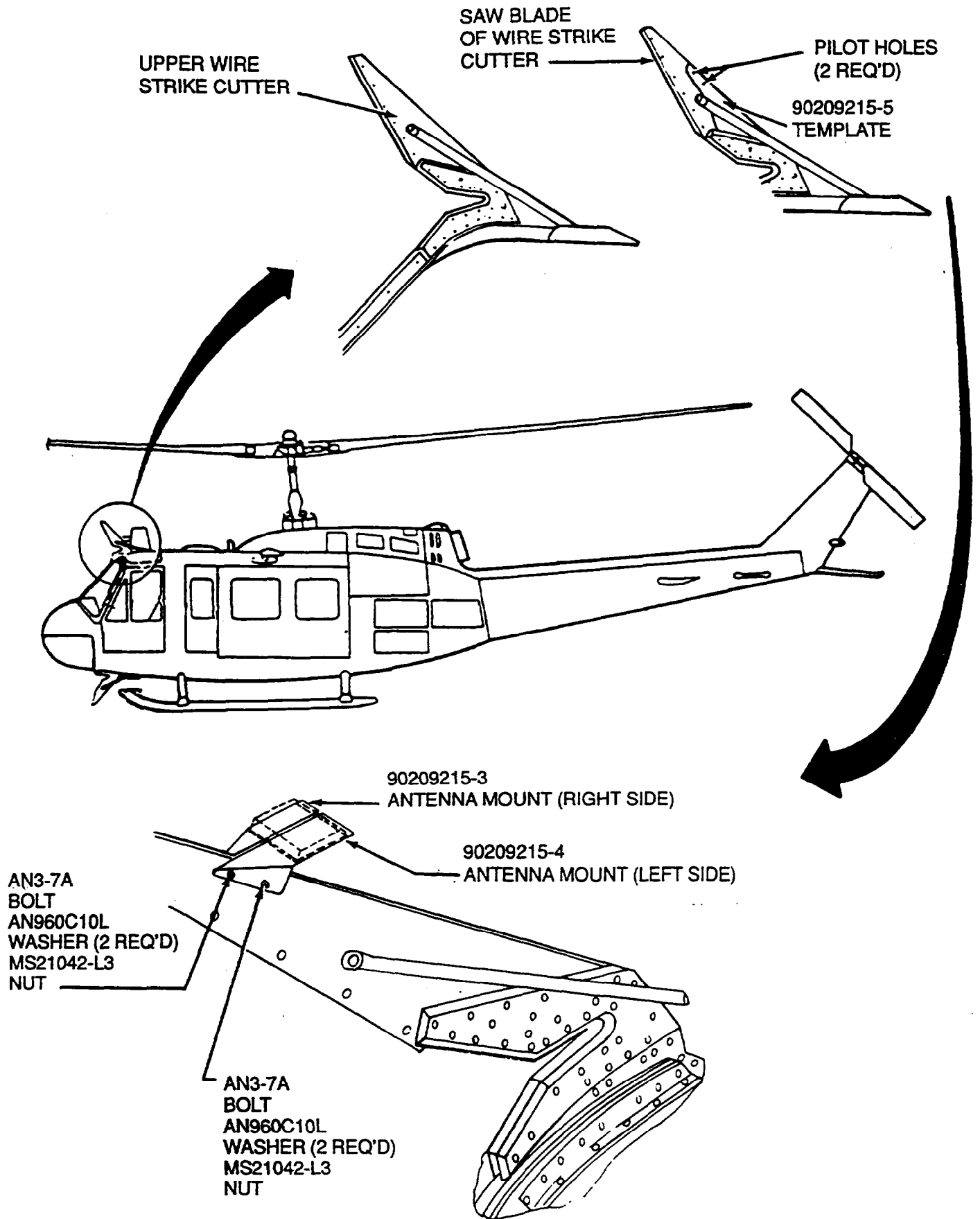

Figure 1. GPS Antenna Mount Installation.

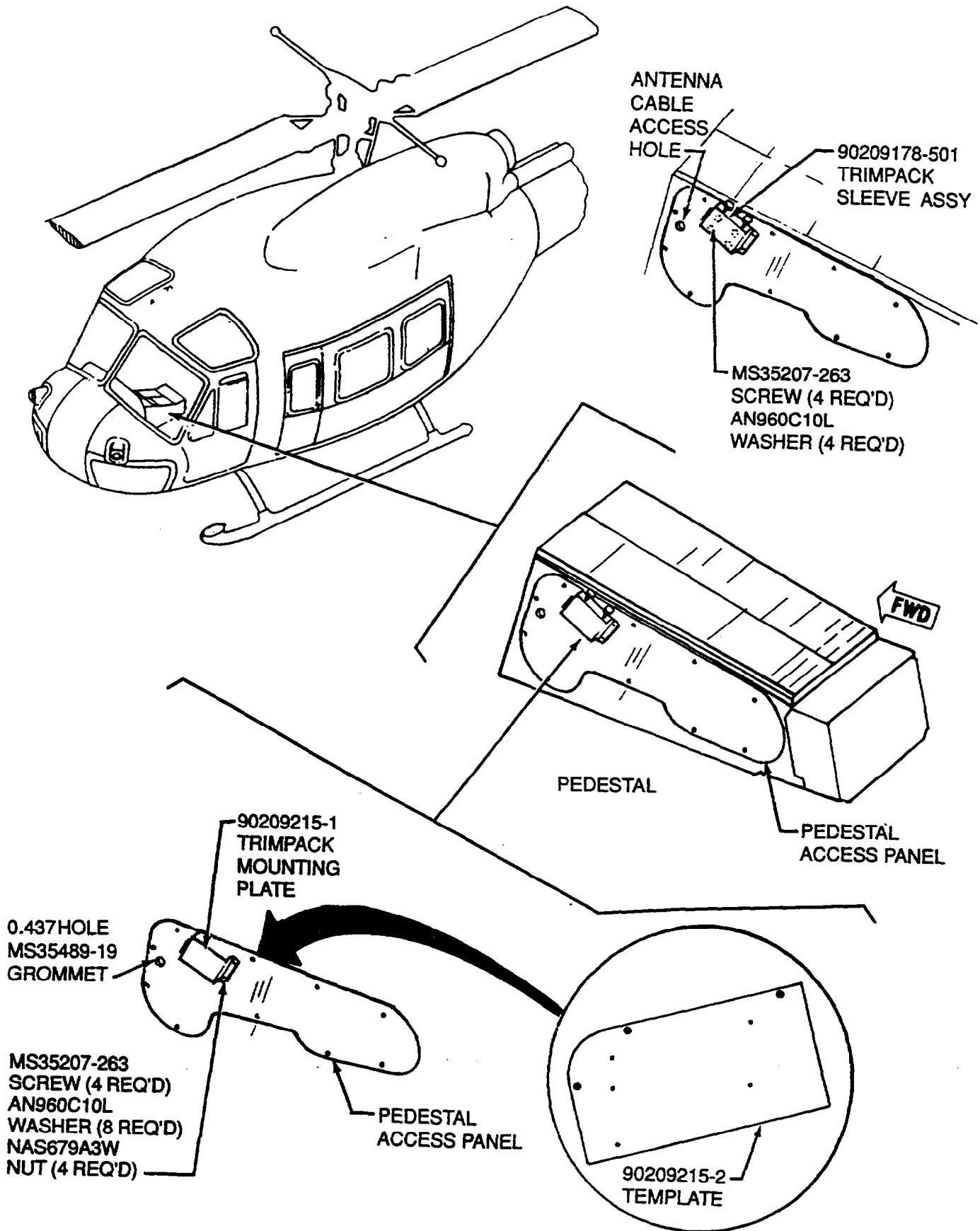

Figure 2. Trimpack Mount and Sleeve Assembly Installation.

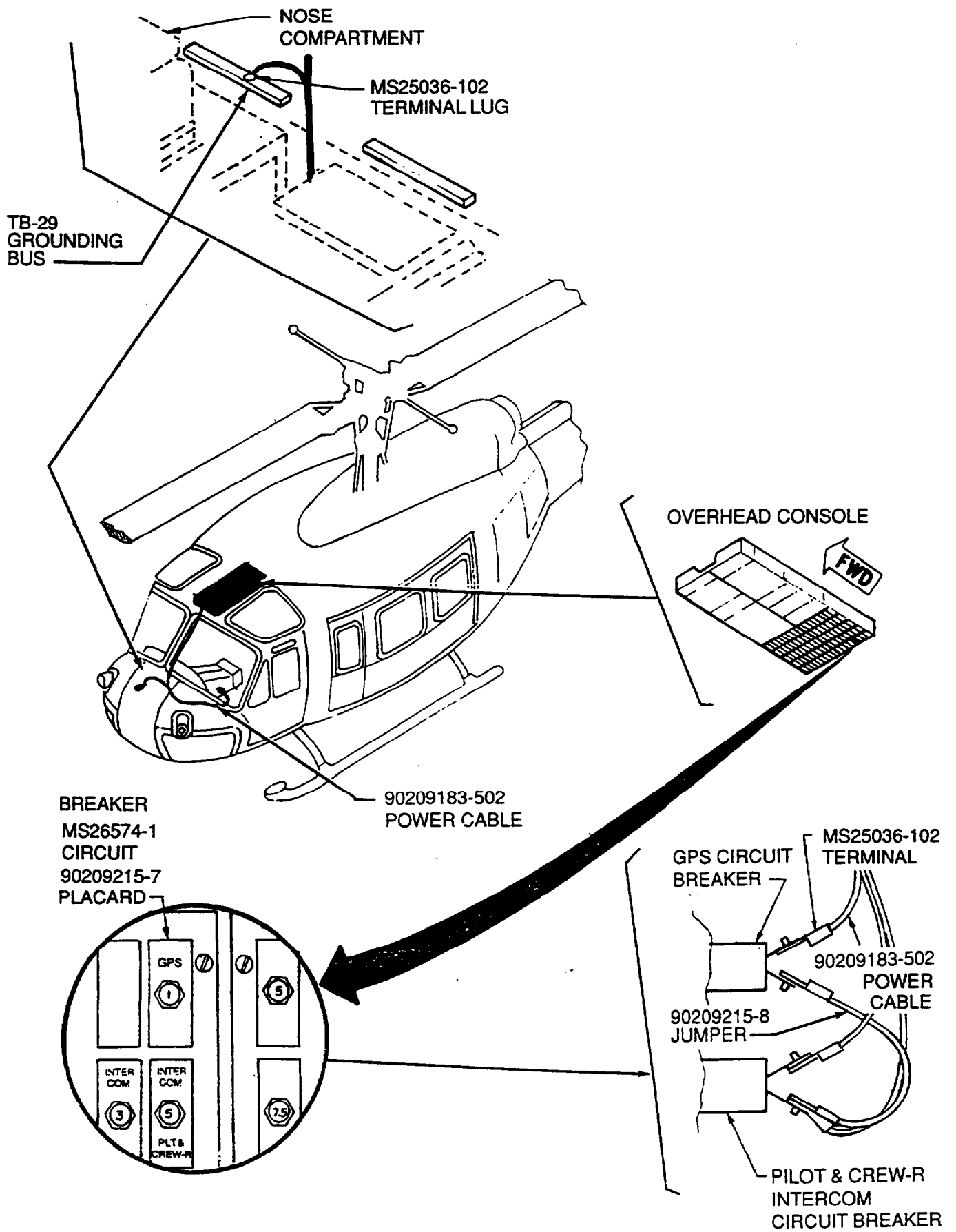

Figure 3. GPS Power Cable and Antenna Cable Installation (Sheet 1 of 2).

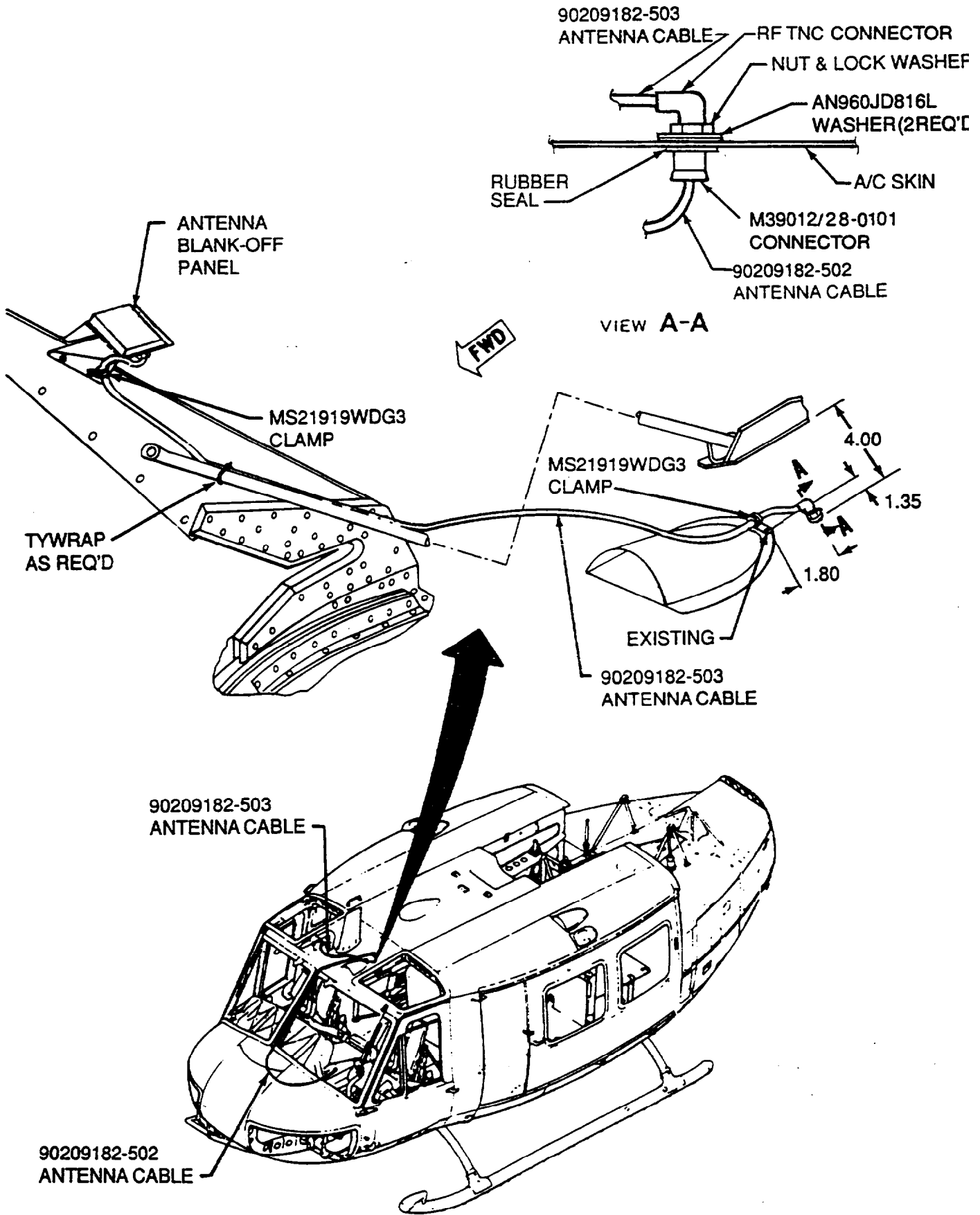

Figure 3. GPS Power Cable and Antenna Cable Installation (Sheet 2 of 2).

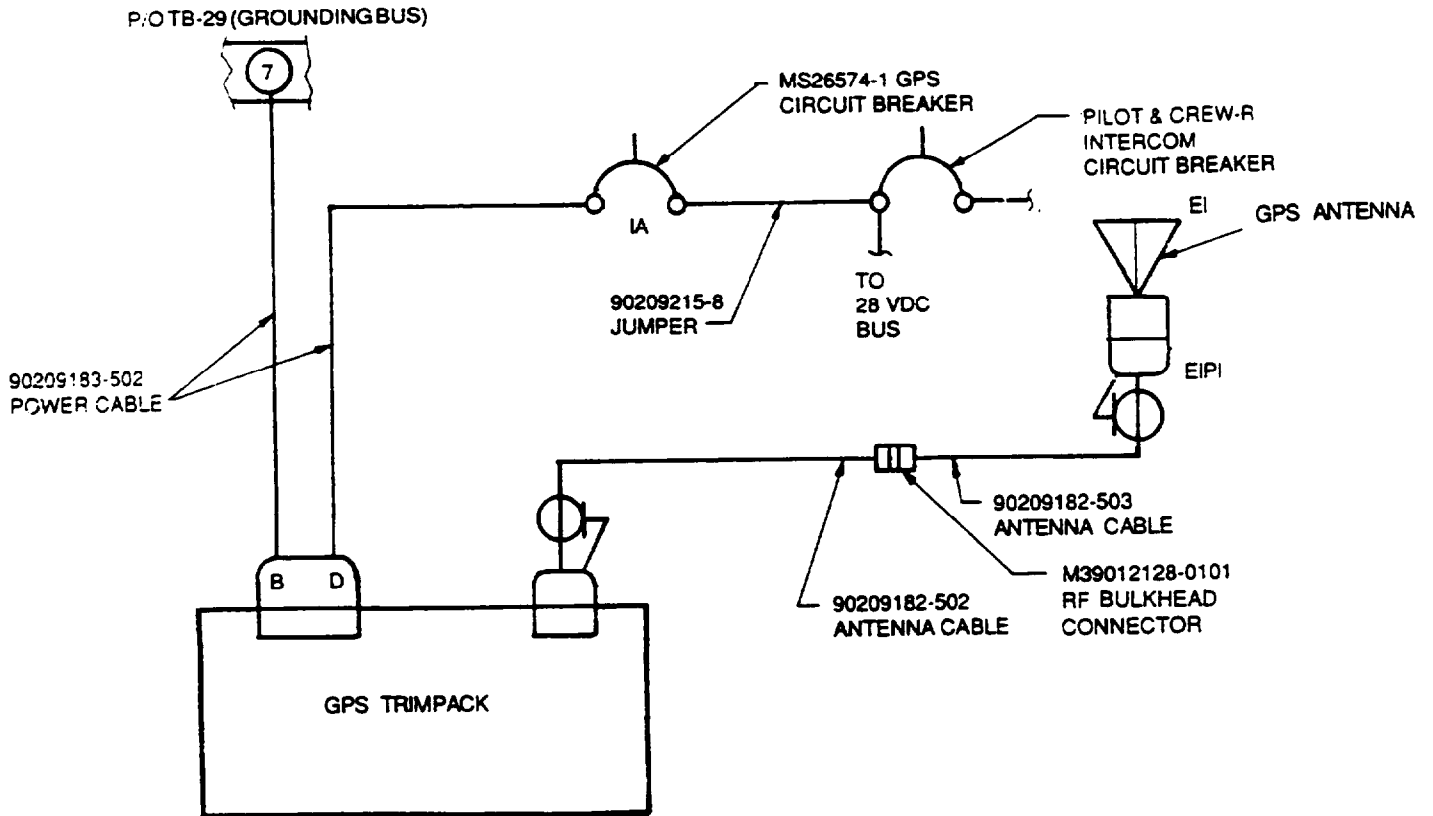

Figure 4. GPS Wiring Diagram

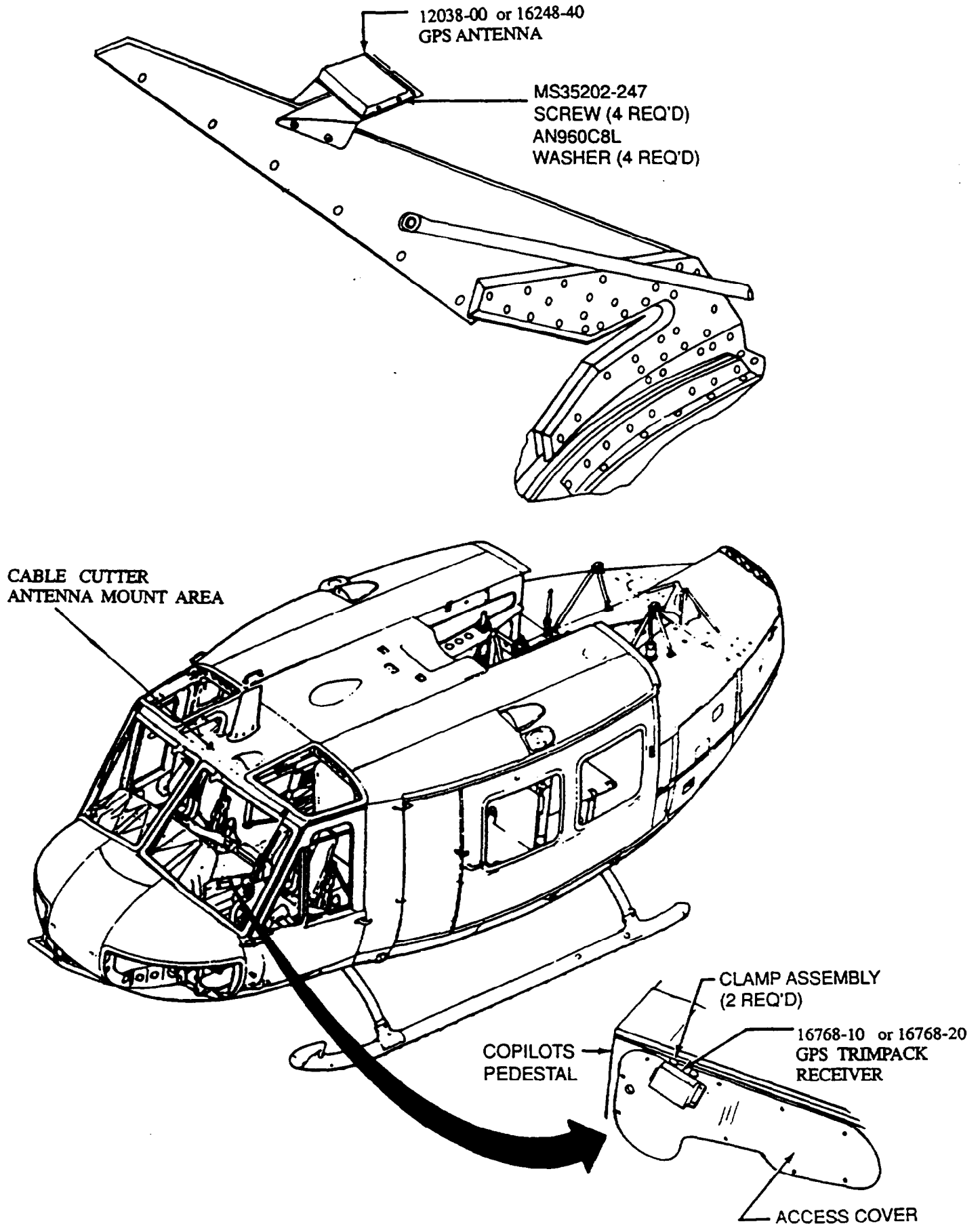
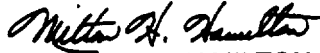

Figure 5. GPS Antenna and Trimpack Receiver Installation.

By Order of the Secretary of the Army:

Official:



MILTON H. HAMILTON

*Administrative Assistant to the
Secretary of the Army*

07785

GORDON R. SULLIVAN
*General, United States Army
Chief of Staff*

DISTRIBUTION:

To be distributed in accordance with DA Form 12-31-E, block no. 3114, requirements for TB 1-1520-210-20-17.

RECOMMENDED CHANGES TO EQUIPMENT TECHNICAL PUBLICATIONS



THEN...JOT DOWN THE
DOPE ABOUT IT ON THIS FORM.
CAREFULLY TEAR IT OUT, FOLD IT
AND DROP IT IN THE MAIL.

SOMETHING WRONG WITH PUBLICATION

FROM: (PRINT YOUR UNIT'S COMPLETE ADDRESS)

DATE SENT

PUBLICATION NUMBER

PUBLICATION DATE

PUBLICATION TITLE

BE EXACT PIN-POINT WHERE IT IS

PAGE
NO.

PARA-
GRAPH

FIGURE
NO.

TABLE
NO.

IN THIS SPACE, TELL WHAT IS WRONG
AND WHAT SHOULD BE DONE ABOUT IT.

TEAR ALONG PERFORATED LINE

PRINTED NAME, GRADE OR TITLE AND TELEPHONE NUMBER

SIGN HERE

THE METRIC SYSTEM AND EQUIVALENTS

WEIGHT MEASURE

1 Centimeter = 10 Millimeters = 0.01 Meters = 0.3937 Inches
 1 Meter = 100 Centimeters = 1000 Millimeters = 39.37 Inches
 1 Kilometer = 1000 Meters = 0.621 Miles

WEIGHTS

1 Gram = 0.001 Kilograms = 1000 Milligrams = 0.035 Ounces
 1 Kilogram = 1000 Grams = 2.2 lb.
 1 Metric Ton = 1000 Kilograms = 1 Megagram = 1.1 Short Tons

LIQUID MEASURE

1 Milliliter = 0.001 Liters = 0.0338 Fluid Ounces
 1 Liter = 1000 Milliliters = 33.82 Fluid Ounces

SQUARE MEASURE

1 Sq. Centimeter = 100 Sq. Millimeters = 0.155 Sq. Inches
 1 Sq. Meter = 10,000 Sq. Centimeters = 10.76 Sq. Feet
 1 Sq. Kilometer = 1,000,000 Sq. Meters = 0.386 Sq. Miles

CUBIC MEASURE

1 Cu. Centimeter = 1000 Cu. Millimeters = 0.06 Cu. Inches
 1 Cu. Meter = 1,000,000 Cu. Centimeters = 35.31 Cu. Feet

TEMPERATURE

$5/9(^{\circ}\text{F} - 32) = ^{\circ}\text{C}$
 212° Fahrenheit is equivalent to 100° Celsius
 90° Fahrenheit is equivalent to 32.2° Celsius
 32° Fahrenheit is equivalent to 0° Celsius
 $9/5^{\circ}\text{C} + 32 = ^{\circ}\text{F}$

APPROXIMATE CONVERSION FACTORS

TO CHANGE	TO	MULTIPLY BY
Inches	Centimeters	2.540
Feet	Meters	0.305
Yards	Meters	0.914
Miles	Kilometers	1.609
Square Inches	Square Centimeters	6.451
Square Feet	Square Meters	0.093
Square Yards	Square Meters	0.836
Square Miles	Square Kilometers	2.590
Acres	Square Hectometers	0.405
Cubic Feet	Cubic Meters	0.028
Cubic Yards	Cubic Meters	0.765
Fluid Ounces	Milliliters	29.573
its	Liters	0.473
arts	Liters	0.946
allons	Liters	3.785
Ounces	Grams	28.349
Pounds	Kilograms	0.454
Short Tons	Metric Tons	0.907
Pound-Feet	Newton-Meters	1.356
Pounds per Square Inch	Kilopascals	6.895
Miles per Gallon	Kilometers per Liter	0.425
Miles per Hour	Kilometers per Hour	1.609

TO CHANGE	TO	MULTIPLY BY
Centimeters	Inches	0.394
Meters	Feet	3.280
Meters	Yards	1.094
Kilometers	Miles	0.621
Square Centimeters	Square Inches	0.155
Square Meters	Square Feet	10.764
Square Meters	Square Yards	1.196
Square Kilometers	Square Miles	0.386
Square Hectometers	Acres	2.471
Cubic Meters	Cubic Feet	35.315
Cubic Meters	Cubic Yards	1.308
Milliliters	Fluid Ounces	0.034
Liters	Pints	2.113
Liters	Quarts	1.057
ers	Gallons	0.264
ms	Ounces	0.035
ograms	Pounds	2.205
Metric Tons	Short Tons	1.102
Newton-Meters	Pounds-Feet	0.738
Kilopascals	Pounds per Square Inch	0.145
meters per Liter	Miles per Gallon	2.354
meters per Hour	Miles per Hour	0.621

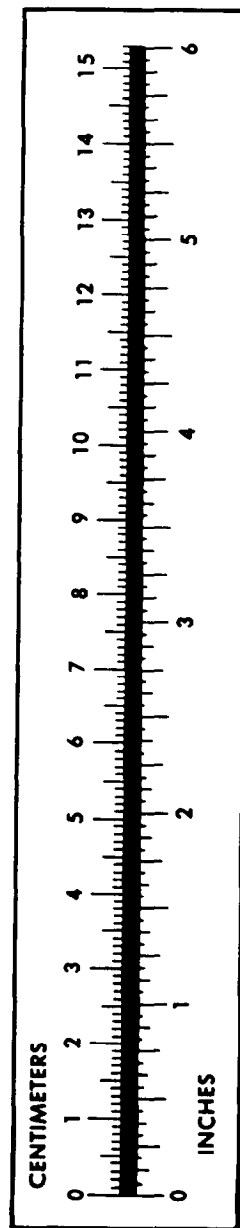

PIN: 051322-000